

PART NAME: KNOB      SCALE: 1:1      DATE: 11/16/92      DR. BY HD

DAVIES MOLDING COMPANY  
CAROL STREAM, ILLINOIS 60188

P/N 1204BQ	
BASE PART	1204-06
SPRING	I0476
INLAY	I0787

THIS DRAWING IS THE PROPERTY OF DAVIES MOLDING COMPANY, IS SUBMITTED SOLELY AS A DESIGN OR ENGINEERING PROJECT. WE ACCEPT NO RESPONSIBILITY WHATSOEVER FOR THE PRACTICAL APPLICATION OF THE PIECES MADE TO THIS DESIGN.

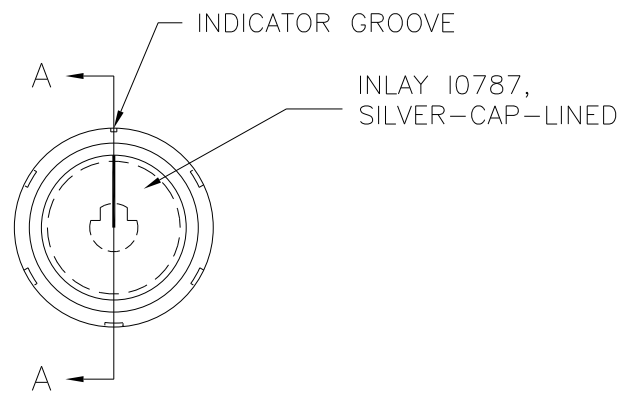

(A)

SECTION A-A

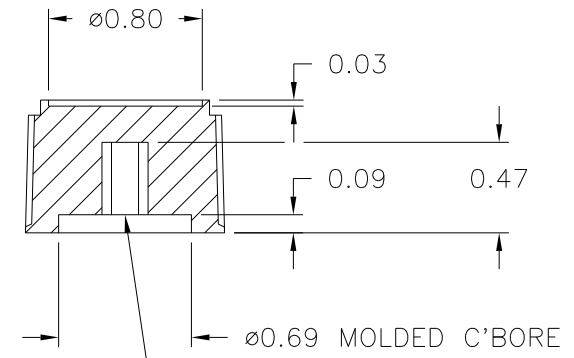
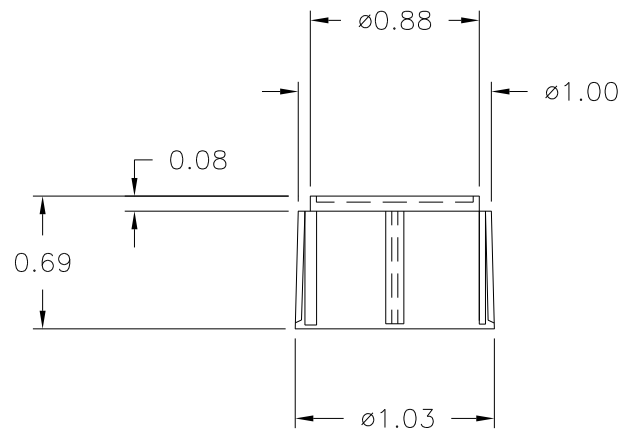

SPRING INSERT I0476 TO ACCOMMODATE  $\phi 0.250$  SHAFT FLATTED TO 5/32.

MATERIAL: G.P. PHENOLIC (B11)  
COLOR: BLACK

TOLERANCES: UNLESS OTHERWISE SPECIFIED	DO NOT SCALE DRAWING	A	REMOVED "MOLDED HOLE DETAIL" VIEW, DRAWN INCORRECTLY	JAM	1/29/04
DECIMALS: X.XXX $\pm$ .005 X.XX $\pm$ .015	MM: X.XX $\pm$ 0.15MM X.X $\pm$ 0.4MM	-	UPDATED/HAD TOOLBOX	ST	5/31/2000
FRACTIONS $\pm$ 1/64	ANG. $\pm$ 1°	-	UPGRADED DWG.	HD	7/10/97
CHANGES					